

IRISH MEDICINES BOARD ACTS 1995 AND 2006

MEDICINAL PRODUCTS(CONTROL OF PLACING ON THE MARKET)REGULATIONS,2007

(S.I. No.540 of 2007)

PA0748/025/010

Case No: 2064402

The Irish Medicines Board in exercise of the powers conferred on it by the above mentioned Regulations hereby grants to

Janssen-Cilag Ltd

50-100 Holmers Farm Way, High Wycombe, Buckinghamshire, HP12 4EG, United Kingdom

an authorisation, subject to the provisions of the said Regulations, in respect of the product

EPREX 40,000 IU/ml solution for injection

The particulars of which are set out in Part I and Part II of the attached Schedule. The authorisation is also subject to the general conditions as may be specified in the said Regulations as listed on the reverse of this document.

This authorisation, unless previously revoked, shall continue in force from **30/03/2010**.

Signed on behalf of the Irish Medicines Board this

A person authorised in that behalf by the said Board.

Part II

Summary of Product Characteristics

1 NAME OF THE MEDICINAL PRODUCT

EPREX 40,000 IU/ml solution for injection.

2 QUALITATIVE AND QUANTITATIVE COMPOSITION

Epoetin alfa*.....40,000 IU/ml (336.0 micrograms per ml)

A vial of 1.0 ml contains 40,000 IU (336.0 micrograms) of epoetin alfa

*produced in Chinese Hamster Ovary (CHO) cells by recombinant DNA technology

For a full list of excipients, see section 6.1.

3 PHARMACEUTICAL FORM

Solution for injection.

Clear, colourless solution

4 CLINICAL PARTICULARS

4.1 Therapeutic Indications

- Treatment of anaemia and reduction of transfusion requirements in adult patients receiving chemotherapy for solid tumours, malignant lymphoma or multiple myeloma, and at risk of transfusion as assessed by the patient's general status (e.g. cardiovascular status, pre-existing anaemia at the start of chemotherapy).
- EPREX can be used to increase the yield of autologous blood from patients in a predonation programme. Its use in this indication must be balanced against the reported risk of thromboembolic events. Treatment should only be given to patients with moderate anaemia (Hb 10-13 g/dl [6.2-8.1 mmol/l], no iron deficiency) if blood saving procedures are not available or insufficient when the scheduled major elective surgery requires a large volume of blood (4 or more units of blood for females or 5 or more units for males).
- EPREX can be used to reduce exposure to allogeneic blood transfusions in adult non-iron deficient patients prior to major elective orthopaedic surgery, having a high perceived risk for transfusion complications. Use should be restricted to patients with moderate anaemia (e.g. Hb 10-13 g/dl) who do not have an autologous predonation programme available and with expected moderate blood loss (900 to 1800 ml).

Good blood management practices should always be used in the perisurgical setting.

4.2 Posology and method of administration

Method of administration

As with any other injectable product, check that there are no particles in the solution or change in colour.

- intravenous injection: over at least one to five minutes, depending on the total dose.

A slower injection is preferable in patients who react to the treatment with “flu-like” symptoms.

Do not administer by intravenous infusion or mixed with other drugs.

- b) subcutaneous injection: a maximum volume of 1 ml at one injection site should generally not be exceeded. In case of larger volumes, more than one site should be chosen for the injection.

The injections are given in the limbs or the anterior abdominal wall.

In those situations in which the physician determines that a patient or caregiver can safely and effectively administer EPREX subcutaneously, instruction as to the proper dosage and administration should be provided.

Refer to section 3. How to use EPREX (instructions on how to inject EPREX) of the package leaflet.

Treatment of patients with chemotherapy induced anaemia:

EPREX should be administered by the subcutaneous route to patients with anaemia (e.g. haemoglobin concentration $\leq 10\text{g/dl}$ (6.2 mmol/l)). Anaemia symptoms and sequelae may vary with age, gender, and overall burden of disease; a physician’s evaluation of the individual patient’s clinical course and condition is necessary.

Due to intra-patient variability, occasional individual haemoglobin values for a patient above and below the desired haemoglobin level may be observed. Haemoglobin variability should be addressed through dose management, with consideration for the haemoglobin target range of 10g/dl (6.2 mmol/l) to 12g/dl (7.5mmol/l). A sustained haemoglobin level of greater than 12g/dl (7.5mmol/l) should be avoided; guidance for appropriate dose adjustment for when haemoglobin values exceed 12g/dl (7.5mmol/l) are described below.

Epoetin alfa therapy should continue until one month after the end of chemotherapy.

The initial dose is 150 IU/kg given subcutaneously 3 times per week. Alternatively, EPREX can be administered at an initial dose of 450 IU/kg subcutaneously once weekly. If the haemoglobin has increased by at least 1 g/dl (0.62 mmol/l) or the reticulocyte count has increased $\geq 40,000\text{ cells}/\mu\text{l}$ above baseline after 4 weeks of treatment, the dose should remain at 150 IU/kg 3 times per week or 450 IU/kg once weekly. If the haemoglobin increase is $<1\text{ g/dl}$ ($<0.62\text{ mmol/l}$) and the reticulocyte count has increased $<40,000\text{ cells}/\mu\text{l}$ above baseline, increase the dose to 300 IU/kg 3 times per week. If after an additional 4 weeks of therapy at 300 IU/kg 3 times per week, the haemoglobin has increased $\geq 1\text{ g/dl}$ ($\geq 0.62\text{ mmol/l}$) or the reticulocyte count has increased $\geq 40,000\text{ cells}/\mu\text{l}$, the dose should remain at 300 IU/kg 3 times per week. However, if the haemoglobin has increased $<1\text{ g/dl}$ ($<0.62\text{ mmol/l}$) and the reticulocyte count has increased $<40,000\text{ cells}/\mu\text{l}$ above baseline, response is unlikely and treatment should be discontinued. The recommended dosing regimen is described in the following diagram:

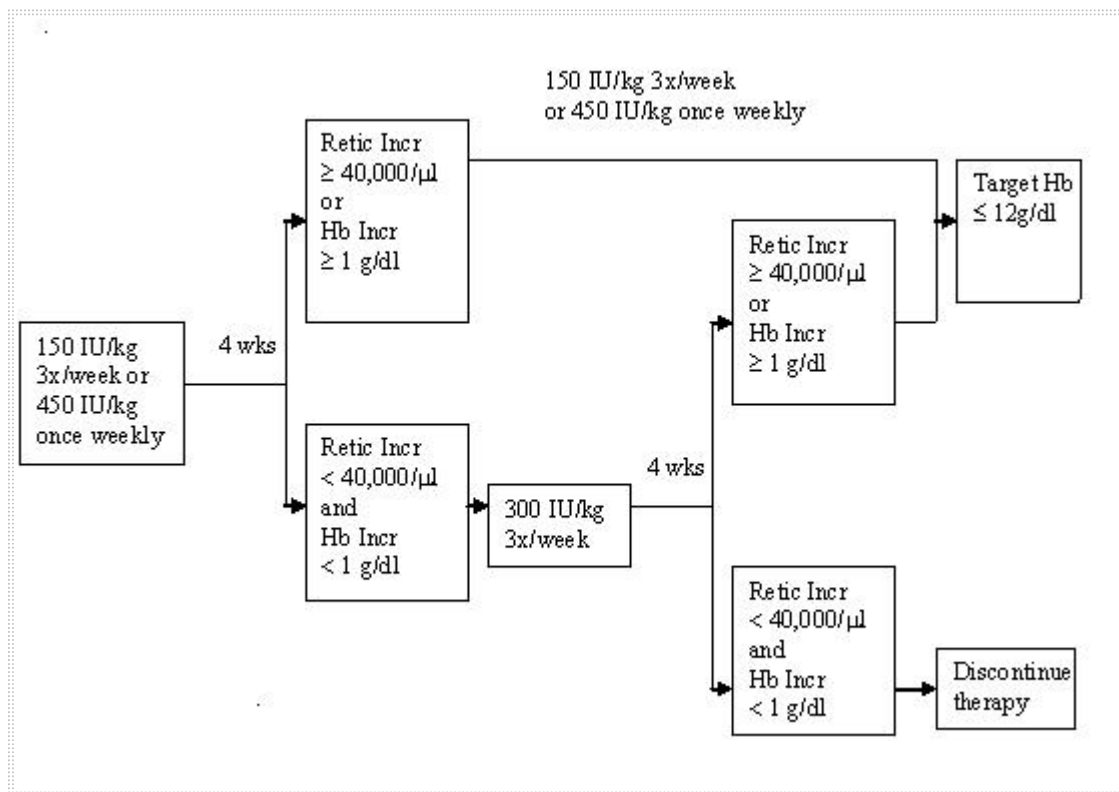

Patients should be monitored closely to ensure that the lowest approved dose of erythropoiesis-stimulating agent (ESA) is used to provide adequate control of the symptoms of anaemia.

Dose adjustment to maintain haemoglobin concentrations between 10g/dl to 12g/dl:

If the haemoglobin is rising by more than 2 g/dl (1.25 mmol/l) per month, or if the haemoglobin exceeds 12 g/dl (7.5 mmol/l), reduce the epoetin alfa dose by about 25 - 50%. If the haemoglobin exceeds 13 g/dl (8.1 mmol/l), discontinue therapy until it falls below 12 g/dl (7.5 mmol/l) and then reinstitute epoetin alfa therapy at a dose 25% below the previous dose.

Adult surgery patients in an autologous predonation programme:

The intravenous route of administration should be used. At the time of donating blood, epoetin alfa should be administered after the completion of the blood donation procedure.

Mildly anaemic patients (haematocrit of 33-39%) requiring predeposit of ≥ 4 units of blood should be treated with epoetin alfa at 600 IU/kg, 2 times weekly for 3 weeks prior to surgery. Using this regimen, it was possible to withdraw ≥ 4 units of blood from 81% of epoetin alfa-treated patients compared to 37% of placebo-treated patients. Epoetin alfa therapy reduced the risk of exposure to homologous blood by 50% compared to patients not receiving epoetin alfa.

All patients being treated with epoetin alfa should receive adequate iron supplementation (e.g. 200 mg oral elemental iron daily) throughout the course of epoetin alfa treatment. Iron supplementation should be started as soon as possible, even several weeks prior to initiating the autologous predeposit, in order to achieve high iron stores prior to starting epoetin alfa therapy.

Adult patients scheduled for major elective orthopaedic surgery:

The subcutaneous route of administration should be used. The recommended dose regimen is 600 IU/kg of epoetin alfa, given weekly for three weeks (days 21, -14 and -7) prior to surgery and on the day of surgery.

In cases where there is a medical need to shorten the lead time before surgery to less than three weeks, 300 IU/kg epoetin alfa should be given daily for 10 consecutive days prior to surgery, on the day of surgery and for four days immediately thereafter. When performing haematologic assessments during the preoperative period, if the haemoglobin level reaches 15 g/dl, or higher, administration of epoetin alfa should be stopped and further dosages should not be given.

Care should be taken to ensure that at the outset of the treatment patients are not iron deficient. All patients being treated with epoetin alfa should receive adequate iron supplementation (e.g. 200 mg oral elemental iron daily) throughout the course of epoetin alfa treatment. If possible, iron supplementation should be started prior to epoetin alfa therapy, to achieve adequate iron stores.

4.3 Contraindications

Patients who develop pure red cell aplasia (PRCA) following treatment with any erythropoietin should not receive EPREX or any other erythropoietin (see Section 4.4 - Pure Red Cell Aplasia).

Uncontrolled hypertension.

All contraindications associated with autologous blood predonation programmes should be respected in patients being supplemented with epoetin alfa.

Hypersensitivity to the active substance or to any of the excipients.

The use of epoetin alfa in patients scheduled for major elective orthopaedic surgery and not participating in an autologous blood predonation programme is contraindicated in patients with severe coronary, peripheral arterial, carotid or cerebral vascular disease, including patients with recent myocardial infarction or cerebral vascular accident.

Surgery patients who for any reason cannot receive adequate antithrombotic prophylaxis.

4.4 Special warnings and precautions for use

General

In all patients receiving epoetin alfa, blood pressure should be closely monitored and controlled as necessary. Epoetin alfa should be used with caution in the presence of untreated, inadequately treated or poorly controllable hypertension. It may be necessary to add or increase anti-hypertensive treatment. If blood pressure cannot be controlled, epoetin alfa treatment should be discontinued.

Epoetin alfa should also be used with caution in the presence of epilepsy and chronic liver failure.

Chronic renal failure and cancer patients on epoetin alfa should have haemoglobin levels measured on a regular basis until a stable level is achieved, and periodically thereafter.

In all patients, haemoglobin levels should be closely monitored due to a potential increased risk of thromboembolic events and fatal outcomes when patients are treated at haemoglobin levels above the target for the indication of use.

There may be a moderate dose-dependent rise in the platelet count within the normal range during treatment with epoetin alfa. This regresses during the course of continued therapy. In addition, thrombocytosis above the normal range has been reported. It is recommended that the platelet count is regularly monitored during the first 8 weeks of therapy.

All other causes of anaemia (iron deficiency, haemolysis, blood loss, vitamin B12 or folate deficiencies) should be considered and treated prior to initiating therapy with epoetin alfa. In most cases, the ferritin values in the serum fall simultaneously with the rise in packed cell volume. In order to ensure optimum response to epoetin alfa, adequate iron stores should be assured:

- oral iron substitution of 200-300 mg/day is recommended for all cancer patients whose transferrin saturation is below 20%.

All of these additive factors of anaemia should also be carefully considered when deciding to increase the dose of epoetin alfa in cancer patients.

Very rarely, development of or exacerbation of porphyria has been observed in epoetin alfa-treated patients. Epoetin alfa should be used with caution in patients with porphyria.

In order to improve the traceability of the ESA all measures necessary and possible to ensure it should be taken (e.g. exact information on the product used should be documented in an appropriate way). Furthermore, patients should only be switched from one ESA to another under appropriate supervision.

Pure Red Cell Aplasia

Antibody-mediated pure red cell aplasia (PRCA) has been reported after months to years of subcutaneous epoetin treatment mainly in chronic renal failure patients. Cases have also been reported in patients with hepatitis C treated with interferon and ribavirin, when ESAs are used concomitantly. EPREX is not approved in the management of anaemia associated with hepatitis C.

In patients developing sudden lack of efficacy defined by a decrease in haemoglobin (1 to 2 g/dl per month) with increased need for transfusions, a reticulocyte count should be obtained and typical causes of non-response (e.g. iron, folate or Vitamin B12 deficiency, aluminium intoxication, infection or inflammation, blood loss and haemolysis) should be investigated.

A paradoxical decrease in haemoglobin and development of severe anaemia associated with low reticulocyte counts should prompt to discontinue treatment with EPREX and perform anti-erythropoietin antibody testing. A bone marrow examination should also be considered for diagnosis of PRCA. No other ESA therapy should be commenced because of the risk of cross-reaction.

Treatment of patients with chemotherapy induced anaemia

Epoetins are growth factors that primarily stimulate red blood cell production. Erythropoietin receptors may be expressed on the surface of a variety of tumour cells. As with all growth factors, there is a concern that epoetins could stimulate the growth of tumours. In several controlled studies, epoetins have not been shown to improve overall survival or decrease the risk of tumour progression in patients with anaemia associated with cancer.

In controlled clinical studies, use of EPREX and other ESAs have shown:

- decreased locoregional control in patients with advanced head and neck cancer receiving radiation therapy when administered to target a haemoglobin of greater than 14 g/dl (8.7 mmol/l),
- shortened overall survival and increased deaths attributed to disease progression at 4 months in patients with metastatic breast cancer receiving chemotherapy when administered to target a haemoglobin of 12-14 g/dl (7.5-8.7 mmol/l),
- increased risk of death when administered to target a haemoglobin of 12 g/dl (7.5 mmol/l) in patients with active malignant disease receiving neither chemotherapy nor radiation therapy. ESAs are not indicated for use in this patient population.

In view of the above, in some clinical situations blood transfusion should be the preferred treatment for the management of anaemia in patients with cancer. The decision to administer recombinant erythropoietin treatment should be based on a benefit-risk assessment with the participation of the individual patient, which should take into account the specific clinical context. Factors that should be considered in this assessment should include the type of tumour and its stage; the degree of anaemia; life-expectancy; the environment in which the patient is being treated; and patient preference (see section 5.1).

In cancer patients receiving chemotherapy, the 2-3 week delay between ESA administration and the appearance of erythropoietin-induced red cells should be taken into account when assessing if epoetin alfa therapy is appropriate (patient at risk of being transfused).

As an increased incidence of thrombotic vascular events (TVEs) has been observed in cancer patients receiving ESAs (see section 4.8), this risk should be carefully weighed against the benefit to be derived from treatment with epoetin alfa particularly in cancer patients with an increased risk of thrombotic vascular events, such as obesity and patients with a prior history of TVEs (e.g. deep venous thrombosis or pulmonary embolism). An investigational study (BEST study) in women with metastatic breast cancer was designed to determine whether epoetin alfa treatment that extended beyond the correction of anaemia could improve treatment outcomes. In that study the incidence of fatal thromboembolic events was higher in patients receiving epoetin alfa than in those receiving placebo.

Surgery patients in autologous predonation programmes

All special warnings and special precautions associated with autologous predonation programmes, especially routine volume replacement, should be respected.

Patients scheduled for major elective orthopaedic surgery

In patients scheduled for major elective orthopaedic surgery the cause of anaemia should be established and treated, if possible, before the start of epoetin alfa treatment. Thrombotic events can be a risk in this population and this possibility should be carefully weighed against the benefit to be derived from the treatment in this patient group.

Patients scheduled for major elective orthopaedic surgery should receive adequate antithrombotic prophylaxis, as thrombotic and vascular events may occur in surgical patients, especially in those with underlying cardiovascular disease. In addition, special precaution should be taken in patients with predisposition for development of DVTs. Moreover, in patients with a baseline haemoglobin of >13 g/dl, the possibility that epoetin alfa treatment may be associated with an increased risk of postoperative thrombotic/vascular events cannot be excluded. Therefore, it should not be used in patients with baseline haemoglobin >13 g/dl.

Chronic renal failure patients

Chronic renal failure patients treated with EPREX by the subcutaneous route should be monitored regularly for loss of efficacy, defined as absent or decreased response to EPREX treatment in patients who previously responded to such therapy. This is characterised by a sustained decrease in haemoglobin despite an increase in EPREX dosage.

This medicinal product contains less than 1 mmol sodium (23 mg) per dose i.e. essentially “sodium free”.

4.5 Interaction with other medicinal products and other forms of interaction

No evidence exists that indicates that treatment with epoetin alfa alters the metabolism of other drugs. However, since cyclosporin is bound by RBCs there is potential for a drug interaction. If epoetin alfa is given concomitantly with cyclosporin, blood levels of cyclosporin should be monitored and the dose of cyclosporin adjusted as the haematocrit rises. No evidence exists that indicates an interaction between epoetin alfa and G-CSF or GM-CSF with regard to haematological differentiation or proliferation of tumour biopsy specimens *in vitro*.

4.6 Pregnancy and lactation

There are no adequate and well-controlled studies in pregnant women. Studies in animals have shown reproduction toxicology (see section 5.3). Consequently, in pregnant or lactating surgical patients participating in an autologous blood predonation programme, the use of epoetin alfa is not recommended.

It is not known whether exogenous epoetin alfa is excreted in human milk. Epoetin alfa should be used with caution in nursing women. A decision on whether to continue/discontinue breast-feeding or to continue/discontinue therapy with epoetin alfa should be made taking into account the benefit of breast-feeding to the child and the benefit of epoetin alfa therapy to the woman.

4.7 Effects on ability to drive and use machines

None.

4.8 Undesirable effects

General

In cancer patients and in chronic renal failure patients the most frequent adverse drug reaction during treatment with epoetin alfa is a dose-dependent increase in blood pressure or aggravation of existing hypertension. Monitoring of the blood pressure should be performed, particularly at the start of therapy (see section 4.4). Other common adverse drug reactions observed in clinical trials of epoetin alfa are deep vein thrombosis, pulmonary embolism, seizures, diarrhoea, nausea, headache, influenza-like illness, pyrexia, rash, and vomiting. Influenza-like illness including headaches, arthralgia, myalgia, and pyrexia may occur especially at the start of treatment. Frequencies may vary depending on the indication (see table below).

Serious adverse drug reactions include venous and arterial thromboses and embolism (including some with fatal outcomes), such as deep venous thrombosis, pulmonary emboli, arterial thrombosis (including myocardial infarction and myocardial ischaemia), retinal thrombosis, and shunt thrombosis (including dialysis equipment). Additionally, cerebrovascular accidents (including cerebral infarction and cerebral haemorrhage) and transient ischaemic attacks have been reported in clinical trials of epoetin alfa.

Aneurysms have been reported.

Hypersensitivity reactions, including cases of rash, urticaria, anaphylactic reaction, and angioneurotic oedema have been reported.

Hypertensive crisis with encephalopathy and seizures, requiring the immediate attention of a physician and intensive medical care, have occurred also during epoetin alfa treatment in patients with previously normal or low blood pressure. Particular attention should be paid to sudden stabbing migraine-like headaches as a possible warning signal.

Antibody-mediated pure red cell aplasia has been very rarely reported in < 1/10,000 cases per patient year after months to years of treatment with EPREX (see section 4.4).

The overall safety profile of EPREX was evaluated in 142 subjects with chronic renal failure and in 765 subjects with cancer who participated in placebo-controlled, double-blind clinical registration trials. Adverse drug reactions reported by $\geq 0.2\%$ of EPREX-treated subjects from these trials, additional clinical trials and from post-marketing experience are listed below by system organ class and frequency.

Frequencies are defined as: Very common ($\geq 1/10$); common ($\geq 1/100$, $< 1/10$); uncommon ($\geq 1/1,000$, $< 1/100$); rare ($\geq 1/10,000$, $< 1/1,000$); very rare ($< 1/10,000$). A frequency is defined as not known if the adverse drug reaction was not reported in the placebo-controlled, double-blind clinical registration trials or when the frequency cannot be estimated from other available data.

Within each frequency grouping, adverse drug reactions are presented in order of decreasing seriousness.

System Organ Class	Frequency	Adverse Drug Reaction
Blood & Lymphatic System Disorders	Uncommon	Thrombocythaemia (cancer patients)
	Frequency not known	Erythropoietin antibody-mediated pure red cell aplasia ¹ Thrombocythaemia (chronic renal failure patients)
Immune System Disorders	Frequency not known	Anaphylactic reaction Hypersensitivity
Nervous System Disorders	Very common	Headache (cancer patients)
	Common	Seizures (chronic renal failure patients) Headache (chronic renal failure patients)
	Uncommon	Cerebral haemorrhage ² Seizures (cancer patients)
	Frequency not known	Cerebrovascular accident ² Hypertensive encephalopathy Transient ischaemic attacks
Eye Disorders	Frequency not known	Retinal thrombosis
Vascular Disorders	Common	Deep vein thrombosis ² (cancer patients) Hypertension
	Frequency not known	Deep vein thrombosis ² (chronic renal failure patients) Arterial thrombosis Hypertensive crisis
Respiratory, Thoracic, and Mediastinal Disorders	Common	Pulmonary embolism ² (cancer patients)
	Frequency not known	Pulmonary embolism ² (chronic renal failure patients)
Gastrointestinal Disorders	Very common	Nausea
	Common	Diarrhoea (cancer patients) Vomiting
	Uncommon	Diarrhoea (chronic renal failure patients)
Skin and Subcutaneous Tissue Disorders	Common	Rash

	Frequency not known	Angioneurotic oedema Urticaria
Musculoskeletal, Connective Tissue, and Bone Disorders	Very common	Arthralgia (chronic renal failure patients)
	Common	Arthralgia (cancer patients)
	Uncommon	Myalgia (cancer patients)
	Frequency not known	Myalgia (chronic renal failure patients)
Congenital and Familial/Genetic Disorders	Frequency not known	Porphyria
General Disorders and Administration Site Conditions	Very common	Pyrexia (cancer patients) Influenza-like illness (chronic renal failure patients)
	Common	Influenza-like illness (cancer patients)
	Frequency not known	Drug ineffective Peripheral oedema Pyrexia (chronic renal failure patients) Injection site reaction
Investigations	Frequency not known	Anti-erythropoietin antibody positive ¹
Injury, Poisoning, and Procedural Complications	Common	Shunt thromboses including dialysis equipment (chronic renal failure patients)

¹The frequency cannot be estimated from clinical trials.

² Including cases with a fatal outcome.

Chronic renal failure patients

In chronic renal failure patients, haemoglobin levels greater than 12 g/dl may be associated with a higher risk of cardiovascular events, including death (see section 4.4).

Shunt thromboses have occurred in haemodialysis patients, especially in those who have a tendency to hypotension or whose arteriovenous fistulae exhibit complications (e.g. stenoses, aneurysms etc).

Cancer patients

An increased incidence of thromboembolic events has been reported in cancer patients receiving ESAs, including epoetin alfa (see section 4.4).

Surgery patients

In patients scheduled for major elective orthopaedic surgery, with a baseline haemoglobin of 10 to 13 g/dl, the incidence of thrombotic/vascular events (most of which were deep vein thrombosis) in the overall patient population of the clinical trials appeared to be similar across the different epoetin alfa dosing groups and placebo group, although the clinical experience is limited.

Moreover, in patients with a baseline haemoglobin of >13 g/dl, the possibility that epoetin alfa treatment may be associated with an increased risk of postoperative thrombotic/vascular events cannot be excluded.

4.9 Overdose

The therapeutic margin of epoetin alfa is very wide. Overdosage of epoetin alfa may produce effects that are extensions of the pharmacological effects of the hormone. Phlebotomy may be performed if excessively high haemoglobin levels occur. Additional supportive care should be provided as necessary.

5 PHARMACOLOGICAL PROPERTIES

5.1 Pharmacodynamic properties

ATC Classification: B03XA01

Erythropoietin is a glycoprotein that stimulates, as a mitosis-stimulating factor and differentiating hormone, the formation of erythrocytes from precursors of the stem cell compartment.

The apparent molecular weight of erythropoietin is 32,000 to 40,000 dalton. The protein fraction of the molecule contributes about 58% and consists of 165 amino acids. The four carbohydrate chains are attached via three N-glycosidic bonds and one O-glycosidic bond to the protein. Epoetin alfa obtained by gene technology is glycosylated and is identical in its amino acid and carbohydrate composition to endogenous human erythropoietin that has been isolated from the urine of anaemic patients.

Epoetin alfa has the highest possible purity according to the present state of the art. In particular, no residues of the cell line used for the production are detectable at the concentrations of the active ingredient that are used in humans.

The biological efficacy of epoetin alfa has been demonstrated in various animal models in vivo (normal and anaemic rats, polycythaemic mice). After administration of epoetin alfa, the number of erythrocytes, the Hb values and reticulocyte counts increase as well as the ⁵⁹Fe-incorporation rate.

An increased ³H-thymidine incorporation in the erythroid nucleated spleen cells has been found in vitro (mouse spleen cell culture) after incubation with epoetin alfa.

It could be shown with the aid of cell cultures of human bone marrow cells that epoetin alfa stimulates erythropoiesis specifically and does not affect leucopoiesis. Cytotoxic actions of epoetin alfa on bone marrow cells could not be detected.

721 cancer patients receiving non-platinum chemotherapy were included in three placebo-controlled studies, 389 patients with haematological malignancies (221 multiple myeloma, 144 non-Hodgkin's lymphoma and 24 other haematological malignancies) and 332 with solid tumours (172 breast, 64 gynaecological, 23 lung, 22 prostate, 21 gastrointestinal, and 30 other tumour types). In two large, open-label studies, 2697 cancer patients receiving non-platinum chemotherapy were included, 1895 with solid tumours (683 breast, 260 lung, 174 gynaecological, 300 gastrointestinal, and 478 other tumour types) and 802 with haematological malignancies.

In a prospective, randomised, double-blind, placebo-controlled trial conducted in 375 anaemic patients with various non-myeloid malignancies receiving non-platinum chemotherapy, there was a significant reduction of anaemia-related sequelae (e.g. fatigue, decreased energy, and activity reduction), as measured by the following instruments and scales: Functional Assessment of Cancer Therapy-Anaemia (FACT-An) general scale, FACT-An fatigue scale, and Cancer Linear Analogue Scale (CLAS). Two other smaller, randomised, placebo-controlled trials failed to show a significant improvement in quality of life parameters on the EORTC-QLQ-C30 scale or CLAS, respectively.

Erythropoietin is a growth factor that primarily stimulates red cell production. Erythropoietin receptors may be expressed on the surface of a variety of tumour cells.

Survival and tumour progression have been examined in five large controlled studies involving a total of 2833 patients, of which four were double-blind placebo-controlled studies and one was an open-label study. The studies either recruited patients who were being treated with chemotherapy (two studies) or used patient populations in which ESAs are not indicated: anaemia in patients with cancer not receiving chemotherapy, and head and neck cancer patients receiving radiotherapy. The target haemoglobin concentration in two studies was >13 g/dl; in the remaining three studies it was 12-14 g/dl. In the open-label study there was no difference in overall survival between patients treated with recombinant human erythropoietin and controls. In the four placebo-controlled studies the hazard ratios for overall survival ranged between 1.25 and 2.47 in favour of controls. These studies have shown a consistent unexplained statistically significant excess mortality in patients who have anaemia associated with various common cancers who received recombinant human erythropoietin compared to controls. Overall survival outcome in the trials could not be satisfactorily explained by differences in the incidence of thrombosis and related complications between those given recombinant human erythropoietin and those in the control group.

A systematic review has also been performed involving more than 9000 cancer patients participating in 57 clinical trials. Meta-analysis of overall survival data produced a hazard ratio point estimate of 1.08 in favour of controls (95% CI: 0.99, 1.18; 42 trials and 8167 patients). An increased relative risk of thromboembolic events (RR 1.67, 95% CI: 1.35, 2.06, 35 trials and 6769 patients) was observed in patients treated with recombinant human erythropoietin. There is an increased risk for thromboembolic events in patients with cancer treated with recombinant human erythropoietin and a negative overall impact on survival cannot be excluded. The extent to which these outcomes might apply to the administration of recombinant human erythropoietin to patients with cancer, treated with chemotherapy to achieve haemoglobin concentrations less than 13 g/dl, is unclear because few patients with these characteristics were included in the data reviewed.

5.2 Pharmacokinetic properties

I.V. route

Measurement of epoetin alfa following multiple dose intravenous administration revealed a half-life of approximately 4 hours in normal volunteers and a somewhat more prolonged half-life in renal failure patients, approximately 5 hours. A half-life of approximately 6 hours has been reported in children.

S.C. route

Following subcutaneous injection, serum levels of epoetin alfa are much lower than the levels achieved following i.v. injection, the levels increase slowly and reach a peak between 12 and 18 hours postdose. The peak is always well below the peak achieved using the i.v. route (approximately 1/20th of the value).

There is no accumulation: the levels remain the same, whether they are determined 24 hours after the first injection or 24 hours after the last injection.

The half-life is difficult to evaluate for the subcutaneous route and is estimated about 24 hours.

The bioavailability of subcutaneous injectable epoetin alfa is much lower than that of the intravenous drug: approximately 20%.

5.3 Preclinical safety data

In some pre-clinical toxicological studies in dogs and rats, but not in monkeys, epoetin alfa therapy was associated with subclinical bone marrow fibrosis (bone marrow fibrosis is a known complication of chronic renal failure in humans and may be related to secondary hyperparathyroidism or unknown factors. The incidence of bone marrow fibrosis was not increased in a study of haemodialysis patients who were treated with epoetin alfa for 3 years compared to a matched control group of dialysis patients who had not been treated with epoetin alfa).

In animal studies, epoetin alfa has been shown to decrease foetal body weight, delay ossification and increase foetal mortality when given in weekly doses of approximately 20 times the recommended human weekly dose. These changes are interpreted as being secondary to decreased maternal body weight gain.

Epoetin alfa did not show any changes in bacterial and mammalian cell culture mutagenicity tests and an in vivo micronucleus test in mice.

Long-term carcinogenicity studies have not been carried out. There are conflicting reports in the literature regarding whether erythropoietins may play a role as tumour proliferators. These reports are based on in vitro findings from human tumour samples, but are of uncertain significance in the clinical situation.

6 PHARMACEUTICAL PARTICULARS

6.1 List of excipients

Polysorbate 80
Glycine
Water for injections

Excipients known to have recognised action or effect (present in this product at < 1 mmol):

Sodium dihydrogen phosphate dihydrate
Disodium phosphate dihydrate
Sodium chloride

6.2 Incompatibilities

In the absence of compatibility studies, this medicinal product must not be mixed with other medicinal products.

6.3 Shelf Life

2 years.

6.4 Special precautions for storage

Store in a refrigerator (2°C to 8°C). This temperature range should be closely maintained until administration to the patient. Store in the original package in order to protect from light. Do not freeze or shake.

For the purpose of ambulatory use, the patient may remove EPREX from the refrigerator and store it not above 25°C for one single period of up to 3 days.

6.5 Nature and contents of container

1.0 ml (40,000 IU) of solution for injection in a vial (type I glass) with stopper (teflon-lined) - pack sizes of 1, 4 & 6.

6.6 Special precautions for disposal of a used medicinal product or waste materials derived from such medicinal product and other handling of the product

Do not administer by intravenous infusion or in conjunction with other drug solutions.

Before use, leave the EPREX vial to stand until it reaches room temperature. This usually takes between 15 and 30 minutes.

The product should not be used, and discarded

- if the seal is broken,
- if the liquid is coloured or you can see particles floating in it,
- if there has been a refrigerator failure, or

- if you know, or think that it may have been accidentally frozen.

The product is for single use only. Only take one dose of EPREX from each vial. Refer to section 3. How to use EPREX (instructions on how to inject EPREX) of the package leaflet.

Any unused product or waste material should be disposed of in accordance with local requirements.

7 MARKETING AUTHORISATION HOLDER

Janssen-Cilag Ltd
50-100 Holmers Farm Way
High Wycombe
Buckinghamshire
HP12 4EG
UK

8 MARKETING AUTHORISATION NUMBER

PA 0748/025/010

9 DATE OF FIRST AUTHORISATION/RENEWAL OF THE AUTHORISATION

Date of first authorisation: 11 June 1999

Date of last renewal: 04 August 2008

10 DATE OF REVISION OF THE TEXT

March 2010