

## Summary of Product Characteristics

### 1 NAME OF THE MEDICINAL PRODUCT

Risperdal Consta 25mg Powder and Solvent for Prolonged-Release Suspension for Intramuscular Injection

### 2 QUALITATIVE AND QUANTITATIVE COMPOSITION

1 vial contains 25 mg risperidone.

1 ml reconstituted suspension contains 12.5 mg of risperidone.

Excipients with known effect: 1 ml reconstituted suspension contains 3 mg sodium.

For a full list of excipients, see section 6.1.

### 3 PHARMACEUTICAL FORM

Powder and solvent for prolonged-release suspension for injection.

*Product sourced from Greece, UK, Romania & Poland*

*Vial with powder.*

White to off-white free flowing powder.

*Pre-filled syringe of solvent for reconstitution.*

Clear, colourless aqueous solution.

### 4 CLINICAL PARTICULARS

As per PA0748/003/010

### 5 PHARMACOLOGICAL PROPERTIES

As per PA0748/003/010

### 6 PHARMACEUTICAL PARTICULARS

#### 6.1 List of excipients

*Microspheres*

(Poly-(d, l-lactide-co-glycolide))

*Solvent*

Polysorbate 20

Carmellose sodium

Disodium hydrogen phosphate dihydrate

Citric acid anhydrous

Sodium chloride

Sodium hydroxide

Water for injection

#### 6.2 Incompatibilities

This medicinal product must not be mixed with other medicinal products except those mentioned in section 6.6.

### 6.3 Shelf life

The shelf life expiry date of this product shall be the date shown on the inner and outer package of the product on the market in the country of origin when stored at 2-8°C.

After reconstitution: Chemical and physical in-use stability has been demonstrated for 24 hours at 25°C.

From a microbiological point of view, the product should be used immediately. If not used immediately, in-use storage times and conditions prior to use are the responsibility of the user and would normally not be longer than 6 hours at 25°C, unless reconstitution has taken place in controlled and validated aseptic conditions.

### 6.4 Special precautions for storage

The entire dose pack should be stored in the refrigerator (2 - 8°C). Do not store above 25°C.

If refrigeration is unavailable, RISPERDAL CONSTA can be stored at temperatures not exceeding 25°C for no more than 7 days prior to administration. Store in original package.

For storage conditions of the reconstituted medicinal product, please see section 6.3.

### 6.5 Nature and contents of container

*For product imported from Greece, UK and Romania*

*Needle-Free Vial Access Device*

One vial containing RISPERDAL CONSTA extended release microspheres

One Alaris SmartSite Needle-Free Vial Access Device for reconstitution

One prefilled syringe containing the solvent for RISPERDAL CONSTA

Two Needles for intramuscular injection (a 21G UTW 1-inch (0.8 x 25 mm) safety needle with needle Needle-Pro safety device for deltoid administration and a 20G TW 2-inch (0.9 x 50 mm) safety needle with Needle-Pro safety device for gluteal administration).

*For product imported from Poland*

*Needle-free Vial Access Device*

One vial containing powder for prolonged-release suspension for injection.

One West-Medimop Vial Adapter® for reconstitution (referred as Vial Adapter).

One prefilled syringe containing the solvent for RISPERDAL CONSTA.

Two Terumo SurGuard®3 needles for intramuscular injection (a 21G UTW 1-inch (0.8 mm x 25 mm)safety needle with needle protection device for deltoid administration and a 20G TW 2-inch (0.9 mm x 51 mm)safety needle with needle protection device for gluteal administration).

### 6.6 Special precautions for disposal and other handling

#### Instructions for Needle-Free Vial Access Device

For product imported from Greece, UK and Romania

**RISPERDAL CONSTA requires close attention to the step-by-step 'Instructions for Use' to help ensure successful administration and help avoid difficulties in the use of the kit.**

RISPERDAL CONSTA extended release microspheres in the vial must be reconstituted **only** in the solvent in the syringe supplied in the dose pack, and must be administered with **only** the appropriate needle supplied in the dose pack for gluteal (2-inch (50 mm) needle) or deltoid (1-inch (25 mm) needle) administration. Do not substitute any components in the dose pack. To assure that the intended dose of risperidone is delivered, the full contents from the vial must be administered. Administration of partial contents may not deliver the intended dose of risperidone. It is recommended to administer immediately after reconstitution.

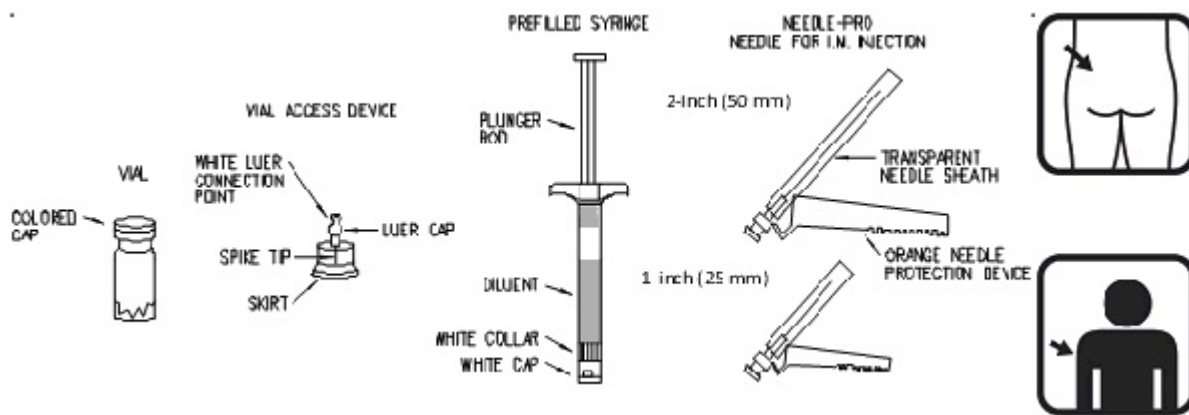

Remove the dose pack of RISPERDAL CONSTA from the refrigerator and allow it to come to room temperature for approximately 30 minutes prior to reconstitution.

Contents of the dose pack:

- One vial containing RISPERDAL CONSTA extended release microspheres
- One Alaris™ SmartSite Needle-Free Vial Access Device for reconstitution
- One prefilled syringe containing the solvent for RISPERDAL CONSTA
- Two needles for intramuscular injection (a 21G UTW 1-inch (0.8 mm x 25 mm) safety needle with Needle-Pro safety device for deltoid administration and a 20G TW 2-inch (0.9 mm x 50 mm) safety needle with Needle-Pro safety device for gluteal administration)

1. Flip off the plastic coloured cap from the vial. Do not remove the grey rubber stopper. Wipe the top of the grey rubber stopper with an alcohol wipe and allow to dry.

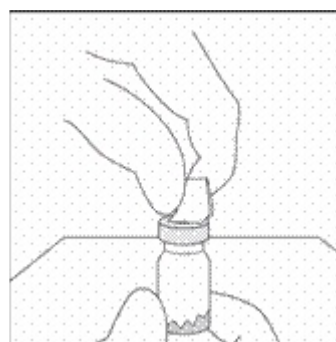

2. Peel back the blister pouch and remove the SmartSite® Needle-Free Vial Access Device by holding between the white luer cap and the skirt.

Do not touch the spike tip of the access device at any time.

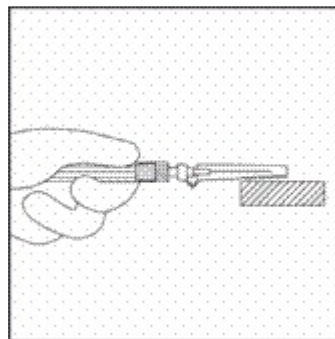
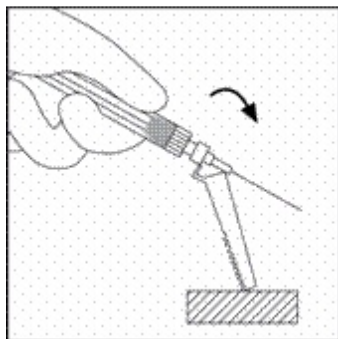

**3. It is very important that the SmartSite<sup>®</sup> Needle-Free Vial Access Device be placed on the vial correctly or the diluent could leak upon transfer to the vial.**

Place the vial on a hard surface. Hold the base of the vial. Orient the SmartSite<sup>®</sup> Needle-Free Vial Access Device vertically over the vial so that the spike tip is at the center of the vial's rubber stopper.

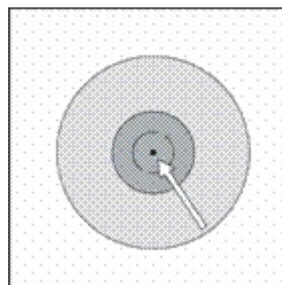
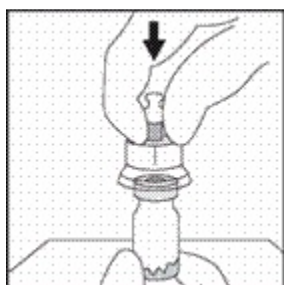

With a straight downward push, press the spike tip of the SmartSite<sup>®</sup> Needle-Free Vial Access Device through the center of the vial's rubber stopper until the device securely snaps onto the vial top.

Correct

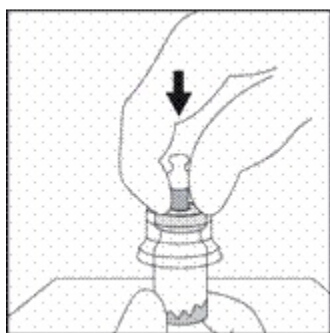

Incorrect

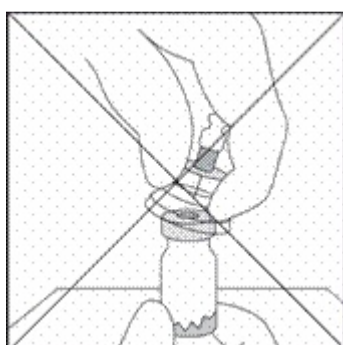

4. **Hold the base of the vial** and swab the syringe connection point (blue circle) of the SmartSite<sup>®</sup> Needle-Free Vial Access Device with an alcohol wipe and allow to dry prior to attaching the syringe to the SmartSite<sup>®</sup> Needle-Free Vial Access Device.

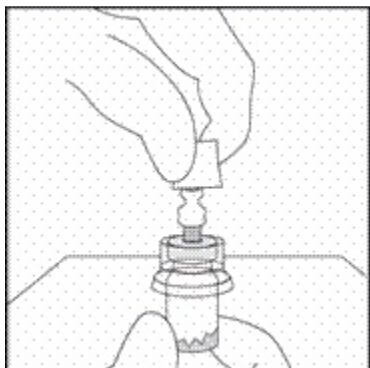

5. The prefilled syringe has a white tip consisting of 2 parts: a white collar and a smooth white cap. To open the syringe, hold the syringe by the white collar and **snap** off the smooth white cap (**DO NOT TWIST OR CUT OFF THE WHITE CAP**). Remove the white cap together with the rubber tip cap inside.

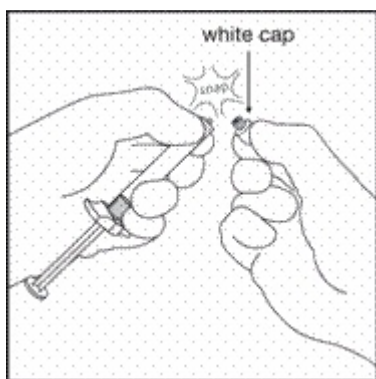

For all syringe assembly steps, hold the syringe only by the white collar located at the tip of the syringe. **Holding the white collar will help to prevent the white collar from getting detached and ensure a good connection to the syringe.** Be careful not to overtighten components when assembling. Overtightening connections may cause syringe component parts to loosen from the syringe body.

6. While holding the **white collar** of the syringe, insert and **press** the syringe tip into the blue circle of the SmartSite<sup>®</sup> Needle-Free Vial Access Device and **twist** in a clockwise motion to secure the connection of the syringe to the SmartSite<sup>®</sup> Needle-Free Vial Access Device (avoid over tightening).

Hold the skirt of the vial access device during attachment to prevent it from spinning.

*Keep the syringe and the SmartSite<sup>®</sup> Needle-Free Vial Access Device aligned.*

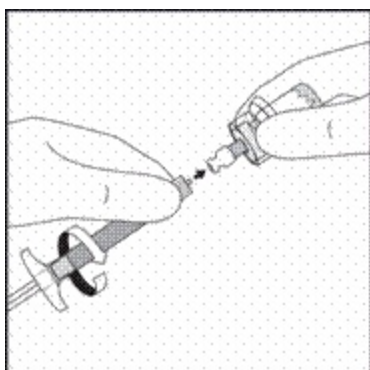

7. Inject the entire contents of the syringe containing the solvent into the vial.

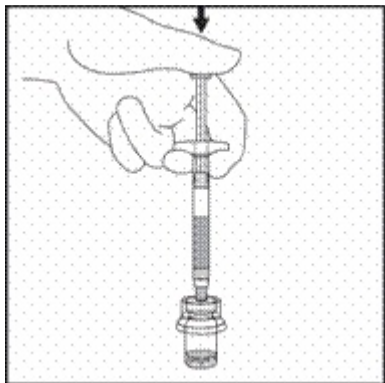

8. Shake the vial **VIGOROUSLY** while holding the plunger rod down with the thumb for a minimum of 10 seconds to ensure a homogeneous suspension.

When properly mixed, the suspension appears uniform, thick, and milky in colour. The microspheres will be visible in liquid, but no dry microspheres remain.

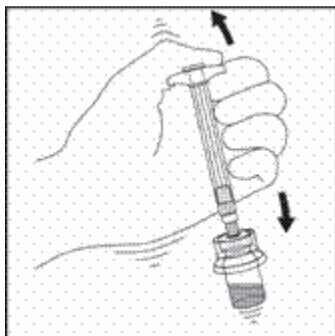

**DO NOT STORE THE VIAL AFTER RECONSTITUTION OR THE SUSPENSION MAY SETTLE.**

9. Invert the vial completely and **SLOWLY** withdraw the entire content of the suspension from the vial into the syringe.

Tear the section of the vial label at the perforation and apply the detached label to the syringe for identification purposes.

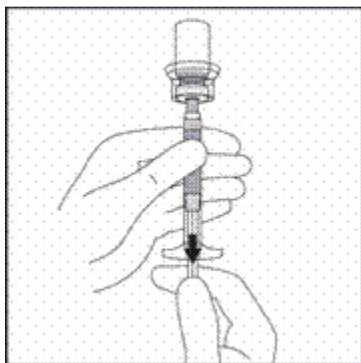

10. While holding the **white collar** of the syringe, unscrew the syringe from the SmartSite<sup>®</sup> Needle-Free Vial Access Device. Discard both the vial and vial access device appropriately.

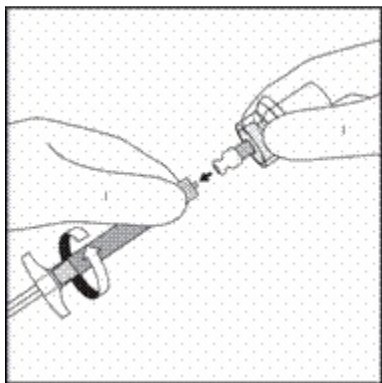

11. Open the needle pack and select the appropriate needle provided with the kit. Do NOT touch the connection part of the needle, only touch the transparent sheath of the needle:

For GLUTEAL injection, select the **20G TW 2-inch** (0.9 mm x 50 mm) needle (longer needle with **yellow** coloured hub).

For DELTOID injection, select the **21G UTW 1-inch** (0.8 mm x 25 mm) needle (shorter needle with **green** coloured hub).

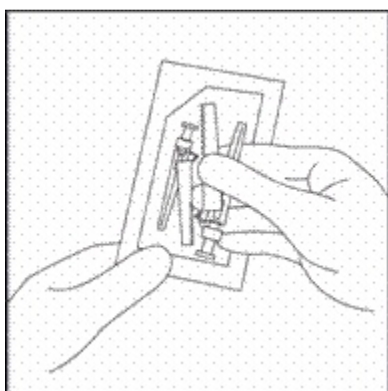

12. To prevent contamination, be careful not to touch the orange Needle-Pro safety device's luer connector. While holding the **white collar** of the syringe, attach the luer connection of the orange Needle-Pro<sup>®</sup> safety device to the syringe with an easy clockwise twisting motion.

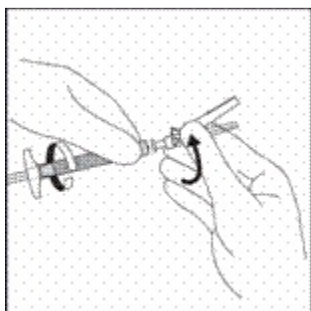

13. While continuing to hold the white collar of the syringe, grasp the transparent needle sheath and seat the needle firmly on the orange Needle-Pro safety device with a push and a clockwise twist. **Seating the needle will help ensure a secure connection between the needle and the orange Needle-Pro safety device while conducting the following steps.**

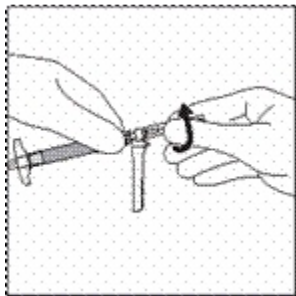

**14. RESUSPENSION OF RISPERDAL CONSTA WILL BE NECESSARY PRIOR TO ADMINISTRATION, AS SETTLING WILL OCCUR OVER TIME ONCE PRODUCT IS RECONSTITUTED. RESUSPEND THE MICROSPHERES IN THE SYRINGE BY SHAKING VIGOROUSLY.**

15. While holding the white collar of the syringe, pull the transparent needle sheath straight away from the needle. **DO NOT TWIST** the sheath as the luer connections may be loosened.

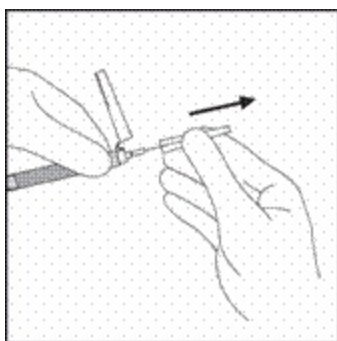

16. Tap the syringe gently to make any air bubbles rise to the top.

Remove air in syringe by depressing the plunger rod, carefully and slowly, while holding the needle in an upright position. Inject the entire contents of the syringe intramuscularly into the selected gluteal or deltoid muscle of the patient immediately. Gluteal injection should be made into the upper-outer quadrant of the gluteal area.

**DO NOT ADMINISTER INTRAVENOUSLY.**

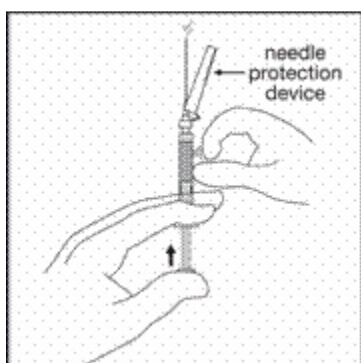

**WARNING:** To avoid a needle stick injury with a contaminated needle:

- Do not use free hand to press the Needle-Pro safety device over the needle.
- Do not intentionally disengage the Needle-Pro safety device.
- Do not attempt to straighten the needle or engage Needle-Pro safety device if the needle is bent or damaged.
- Do not mishandle the Needle-Pro safety device as it may cause the needle to protrude from the Needle-Pro safety device.

17. After injection is complete, press the needle into the orange Needle-Pro safety device using a one-handed technique. Perform a one-handed technique by GENTLY pressing the orange Needle-Pro safety device against a flat surface. AS THE ORANGE NEEDLE-PRO SAFETY DEVICE IS PRESSED, THE NEEDLE WILL FIRMLY ENGAGE INTO THE ORANGE NEEDLE-PRO SAFETY DEVICE. Visually confirm that the needle is fully engaged into the orange Needle-Pro safety device before discarding. Discard needle appropriately. Also discard the other (unused) needle provided in the dose pack.

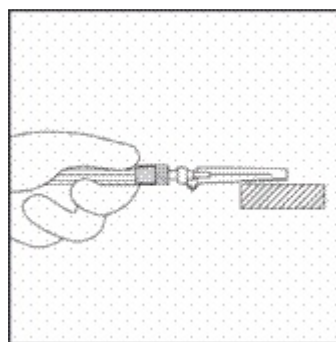
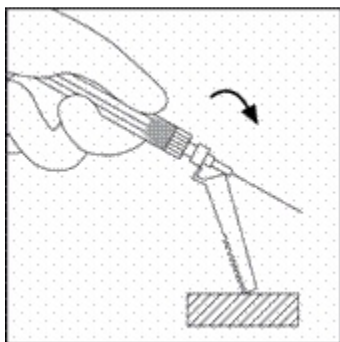

**Do Not Reuse:** Medical devices require specific material characteristics to perform as intended. These characteristics have been verified for single use only. Any attempt to re-process the device for subsequent re-use may adversely affect the integrity of the device or lead to deterioration in performance.

Any unused product or waste material should be disposed of in accordance with local requirements.

### **Instructions for Needle-Free Vial Access Device**

#### **For product imported from Poland**

#### **Important information**

Risperdal Consta requires close attention to these step-by-step Instructions for Use to help ensure successful administration.

#### **Use components provided**

The components in this dose pack are specifically designed for use with Risperdal Consta. Risperdal Consta must be reconstituted only in the diluent supplied in the dose pack.

**Do not** substitute ANY components of the dose pack.

#### **Do not store suspension after reconstitution**

Administer dose as soon as possible after reconstitution to avoid settling.

#### **Proper dosing**

The entire contents of the vial must be administered to ensure intended dose of Risperdal Consta is delivered.

**SINGLE-USE DEVICE**

Do not reuse. Medical devices require specific material characteristics to perform as intended. These characteristics have been verified for single use only. Any attempt to re-process the device for subsequent re-use may adversely affect the integrity of the device or lead to deterioration in performance.

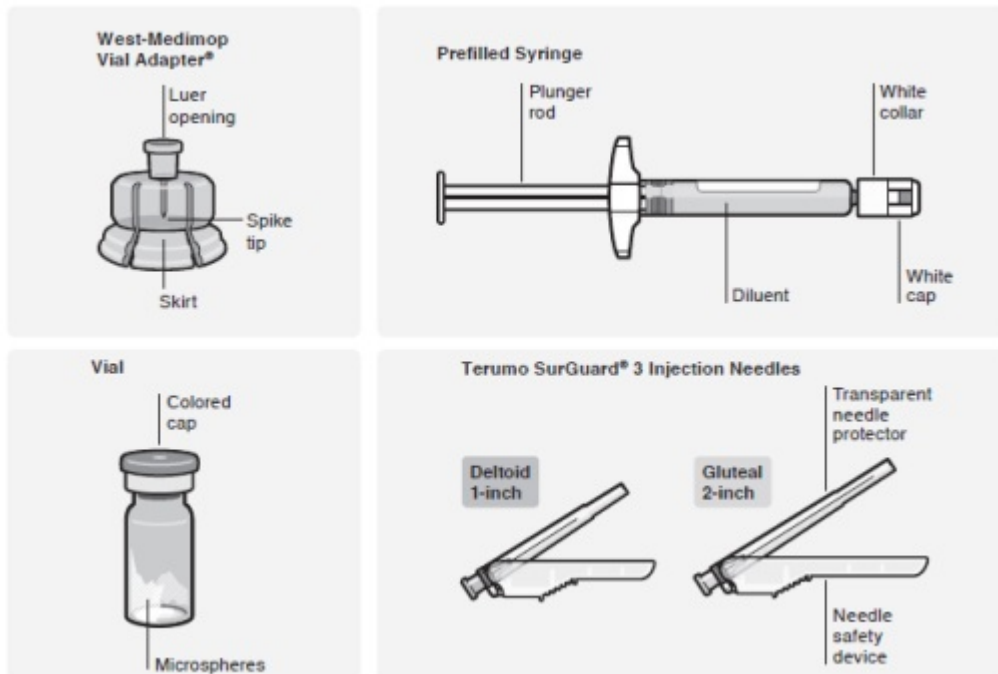
**Step 1 Assemble components****Take out the dose pack****Wait 30 minutes**

Remove dose pack from the refrigerator and allow to sit at room temperature for at least **30 minutes** before reconstituting.

**Do not** warm any other way.

**Connect vial adapter to vial****Remove cap from vial**

Flip off coloured cap from vial.

Wipe top of the grey stopper with an alcohol swab.

Allow to air dry.

**Do not** remove grey rubber stopper.

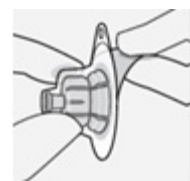
**Prepare vial adapter**

Hold sterile blister as shown.

Peel back and remove paper backing.

**Do not** remove vial adapter from blister.

**Do not** touch spike tip at any time. This will result in contamination.

**Connect vial adapter to vial**

Place vial on a hard surface and hold by the base. Center vial adapter over the grey rubber stopper. Push vial adapter straight down onto vial top until it snaps securely into place.

**Do not** place vial adapter on at an angle or diluent may leak





upon transfer to the vial.

### Connect prefilled syringe to vial adapter



#### Remove sterile blister

Remove vial adaptor from sterile blister only when you are ready to remove the white cap from the prefilled syringe.

Keep vial vertical to prevent leakage.

Hold base of vial and pull up on the sterile blister to remove.

**Do not** shake.

**Do not** touch exposed luer opening on vial adapter.

This will result in contamination.



#### Use proper grip

Hold by white collar at the tip of the syringe.

**Do not** hold syringe by the glass barrel during assembly.



#### Remove cap

Holding the white collar, snap off the white cap.

**Do not** twist or cut off the white cap.

**Do not** touch syringe tip. This will result in Contamination.

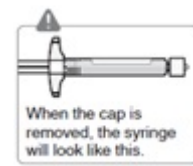

The broken-off cap can be discarded.



#### Connect syringe to vial adapter

Hold vial adapter by skirt to keep stationary.

Hold syringe by white collar then insert tip into the luer opening of the vial adapter.

**Do not** hold the glass syringe barrel.

This may cause the white collar to loosen or detach.

Attach the syringe to the vial adapter with a firm clockwise twisting motion until it feels snug.

**Do not** over-tighten. Over-tightening may cause the syringe tip to break.

### Step 2 Reconstitute microspheres



#### Inject diluent

Inject entire amount of diluent from syringe into the vial.



#### Suspend microspheres in diluent

Continuing to hold down the plunger rod, shake vigorously for at least 10 seconds, as shown.

Check the suspension. When properly mixed, the suspension appears

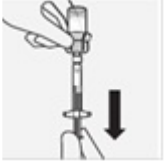

uniform, thick and milky in colour. Microspheres will be visible in the liquid. Immediately proceed to the next step so suspension does not settle.

**Transfer suspension to syringe**

Invert vial completely. Slowly pull plunger rod down to withdraw entire contents from the vial into the syringe.

**Remove vial adapter**

Hold white collar on the syringe and unscrew from vial adapter. Tear section of the vial label at the perforation. Apply detached label to the syringe for identification purposes. Discard both vial and vial adapter appropriately.

**Step 3 Attach needle****Select appropriate needle**

Choose needle based on injection location (gluteal or deltoid).

**Attach needle**

Peel blister pouch open part way and use to grasp the base of the needle, as shown.

Holding the white collar on the syringe, attach syringe to needle luer connection with a firm clockwise twisting motion until snug.

**Do not** touch needle luer opening. This will result in contamination.

**Resuspend microspheres**

Fully remove the blister pouch.

Just before injection, shake syringe vigorously again, as some settling will have occurred.

**Step 4 Inject dose****Remove transparent needle protector**

Move the needle safety device back towards the syringe, as shown.

Then hold white collar on syringe and carefully pull the transparent needle protector straight off.

**Do not** twist transparent needle protector, as the luer connection may loosen.

**Remove air bubbles**

Hold syringe upright and tap gently to may any air bubbles rise to the top.

Slowly and carefully press plunger rod upward to remove air.

**Inject**

Immediately inject entire contents of syringe intramuscularly (IM) into the gluteal or deltoid muscle of the patient.

Gluteal injection should be made into the upper-outer quadrant of the gluteal area.

**Do not administer intravenously.**



**Secure needle in safety device**

Using one hand, place needle safety device at a 45 degree angle on a hard, flat surface. Press down with a firm, quick motion until needle is fully engaged in safety device.

**Avoid needle stick injury:**

**Do not** use two hands.

**Do not** intentionally disengage or mishandle the needle safety device.

**Do not** attempt to straighten the needle or engage the safety device if the needle is bent or damaged.



**Properly dispose of needles**

Check to confirm needle safety device is fully engaged.

Discard in an approved sharps container.

Also discard the unused needle provided in the dose pack.

**7 PARALLEL PRODUCT AUTHORISATION HOLDER**

PCO Manufacturing  
Unit 10, Ashbourne Business Park  
Rath  
Ashbourne  
Co. Meath  
Ireland

**8 PARALLEL PRODUCT AUTHORISATION NUMBER**

PPA0465/274/001

**9 DATE OF FIRST AUTHORISATION/RENEWAL OF THE AUTHORISATION**

Date of first authorisation: 5<sup>th</sup> August 2011

**10 DATE OF REVISION OF THE TEXT**

April 2016