

Package leaflet: Information for the user
Trimethoprim 10 mg/ml Oral Suspension
trimethoprim

Read all of this leaflet carefully before you start taking this medicine because it contains important information for you.

- Keep this leaflet. You may need to read it again.
- If you have any further questions, ask your doctor or pharmacist.
- This medicine has been prescribed for you only. Do not pass it on to others. It may harm them, even if their signs of illness are the same as yours.
- If you get any side effects, talk to your doctor or pharmacist. This includes any possible side effects not listed in this leaflet. See section 4.

What is in this leaflet

1. What Trimethoprim is and what it is used for
2. What you need to know before you take Trimethoprim
3. How to take Trimethoprim
4. Possible side effects
5. How to store Trimethoprim
6. Contents of the pack and other information

1. WHAT TRIMETHOPRIM IS AND WHAT IT IS USED FOR

Trimethoprim Oral Suspension contains Trimethoprim which is an antibiotic. It is used to treat certain infections caused by bacteria sensitive to trimethoprim such as:

- urinary tract infections
- chest infections.

Trimethoprim may also be given to patients who often suffer from urinary tract infections, to stop the infections from returning.

Trimethoprim is indicated in adults and children aged over 12 years and children under 12 years (>6 weeks to <12 years old).

2. WHAT YOU NEED TO KNOW BEFORE YOU TAKE TRIMETHOPRIM

Do not take Trimethoprim if you:

- are allergic to trimethoprim or any of the other ingredients of this medicine (listed in section 6)
- are pregnant or planning to become pregnant
- have a blood disorder.

Do not give Trimethoprim to very young babies (premature babies or babies less than 6 weeks old.)

If any of the above apply to you, speak to your doctor or pharmacist.

Warnings and precautions

Talk to your doctor or pharmacist before taking Trimethoprim if you:

- have a folic acid deficiency
- have kidney problems or are having dialysis treatment

- have high concentration of potassium ions in the blood
- are elderly
- are breast-feeding.

Trimethoprim can increase potassium blood levels. Patients at risk of increased potassium blood levels include those with kidney problems, poorly controlled diabetes, or those on certain medicines or potassium supplements. The symptoms of very high potassium blood levels (severe hyperkalaemia) might include muscle cramps, irregular heart rhythm, diarrhoea, nausea, dizziness or headache. Your doctor may perform blood tests to monitor your potassium blood levels.

Other medicines and Trimethoprim

Tell your doctor or pharmacist if you are taking, have recently taken or might take any other medicines.

Some medicines may be affected by Trimethoprim or they may affect how well Trimethoprim will work.

Tell your doctor or pharmacist if you are taking:

- anticonvulsants (for epilepsy or related conditions), particularly phenytoin
- diuretics (water tablets such as Bendroflumethiazide, eplerenone, spironolactone, amiloride or triamterene)
- medicines likely to increase the amount of potassium in your blood (e.g. potassium supplements, ACE-inhibitors such as lisinopril, angiotensin II antagonists, heparin)
- digoxin (a medicine used to treat certain heart conditions)
- medicines to stop the blood clotting or thin the blood (e.g. warfarin)
- ciclosporin (a medicine used to suppress the immune system)
- folate antagonists, medicines used to treat rheumatoid arthritis or cancer (e.g. methotrexate or 5-fluorouracil)
- oestrogen-containing contraceptives.
Ask your doctor or pharmacist about alternative contraception
- medicines likely to depress bone marrow (e.g. azathioprine, mercaptopurine)
- procainamide (a medicine used to treat certain heart conditions)
- repaglinide (a medicine used to treat diabetes)
- dapsone (a medicine used to treat skin infections)
- pyrimethamine (a medicine used to prevent malaria)
- lamivudine (a medicine used to treat HIV)
- oral typhoid vaccine (a medicine used to protect against typhoid fever).

Blood monitoring may be carried out if taking these drugs with Trimethoprim.

If you are unsure whether you are taking any of the above medicines, show the containers of the medicines you are taking to your doctor or pharmacist.

Pregnancy and breast-feeding

DO NOT take Trimethoprim if you are pregnant as it may affect your unborn baby.

Trimethoprim can pass into breast milk, therefore care should be taken if breast-feeding.

If you are pregnant or breast-feeding, think you may be pregnant or are planning to have a baby, ask your doctor or pharmacist for advice before taking this medicine.

Driving and using machines

Trimethoprim is unlikely to affect your ability to use machinery or to drive.

Trimethoprim contains

- **Liquid maltitol**

If you have been told by your doctor that you have an intolerance to some sugars, contact your doctor before taking this medicinal product.

Liquid maltitol may have a mild laxative effect.

Calorific value 2.3 kcal/g maltitol.

- **Methyl hydroxybenzoate sodium and propyl hydroxybenzoate sodium**

This medicine contains 1.72 mg of methyl hydroxybenzoate sodium and 0.45 mg of propyl hydroxybenzoate sodium per ml. May cause allergic reactions (possibly delayed).

- **Sodium**

This medicine contains less than 1 mmol sodium (23 mg) per ml, that is to say essentially 'sodium-free'.

3. HOW TO TAKE TRIMETHOPRIM

Always take this medicine exactly as your doctor or pharmacist has told you. Your doctor will decide on the appropriate dose to suit your condition. If you suffer from a kidney complaint, your doctor will decide the correct dosage for you. Check with your doctor or pharmacist if you are not sure.

- Take the suspension by mouth
- Shake the bottle gently before taking the medicine. It is important to shake up any sediment but do not shake it too hard.

TO THE PATIENT: INSTRUCTIONS FOR USE OF THE SYRINGE

1. Remove the cap from the bottle by pushing the cap down and turning it anti-clockwise.
2. Push the plastic adapter into the neck of the bottle (Fig 1). Note: The adapter must then always stay in the bottle.
3. Take the syringe and check the plunger is fully down.
4. Keep the bottle upright and insert the oral syringe firmly into the plastic adapter (Fig 2).
5. Turn the whole bottle with the syringe upside down.
6. Pull the plunger slowly out to the mark showing the number of millilitres (ml) you need for your dose (Fig 3).
7. Turn the whole bottle with the syringe the right way up and take the syringe out of the bottle.
8. Place the syringe inside the mouth and press the plunger slowly to gently release the medicine.
9. After use, the bottle cap should be replaced leaving the adapter in place. The syringe should be washed and dried.

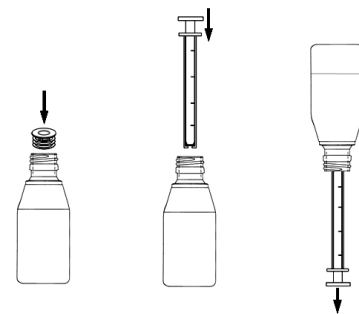

Fig 1

Fig 2

Fig 3

The recommended dose is:

Doses to treat urinary or chest infections

Adults and children over 12 years: the usual dose is 20ml (four 5ml syringes) twice a day for 7-10 days.

Children under the age of 12 years: the usual dose may be given twice a day for 7-10 days:

Age	Usual dose given twice a day for 7 to 10 days
6 weeks to 5 months	2.5ml (half a 5ml syringe)
6 months to 3 years	2.5ml-5ml (half to one 5ml syringe)

4 years to 7 years	5ml-7.5ml (one to one-and-a-half 5ml syringes)
8 years to 12 years	7.5ml-12.5ml (one-and-a-half to two-and-a-half 5ml syringes)

Trimethoprim is NOT recommended for use in infants under 6 weeks of age.

Your doctor may tell you to double the dose on the first day.

Doses to prevent urinary infections

Adults and children over 12 years: the usual dose is 10ml (two 5ml syringes) at night. Your doctor may tell you to take another 10ml in the morning as well.

Children under 12 years: your doctor will tell you the correct dose based on the child's weight, to be taken once a day, in the evening.

Elderly

Your doctor may prescribe a lower dose. You will be advised by your doctor.

Taking Trimethoprim long term

If you are taking this for long periods, blood tests may be carried out. The doctor may also prescribe an additional drug, folic acid, for you to take.

If you take more Trimethoprim than you should

Tell your doctor, pharmacist or nearest hospital casualty department immediately. Take the bottle and any remaining suspension with you so that people can see what you have taken. Do this even if you feel well.

If you forget to take Trimethoprim

If you suffer from a kidney complaint and you forget to take a dose, ask your doctor or pharmacist for advice. Otherwise, if you forget to take a dose, take it as soon as you remember, but if it is almost time for your next dose, skip the missed dose and continue as usual. Do not take a double dose to make up for a forgotten dose.

If you stop taking Trimethoprim

Do not stop just because you feel better. If you stop too soon, the infection may come back. Keep taking the suspension until the prescribed course is finished.

If you have any further questions on the use of this medicine, ask your doctor or pharmacist.

4. POSSIBLE SIDE EFFECTS

Like all medicines, this medicine can cause side effects, although not everybody gets them. Do not be alarmed by this list of possible side effects. You may not experience any of them. All of the side effects listed have a frequency of not known: frequency cannot be estimated from the available data.

STOP taking the suspension and **seek medical help immediately** if you have any of the following allergic reactions:

- difficulty breathing or swallowing, swelling of the face, lips, tongue or throat
- severe itching of the skin, with a red rash or raised lumps
- blistering of the mouth, eyes, or genital region, patchy areas of rash, peeling skin, fever or sore throat.

Seek immediate medical attention if you have any of the following symptoms:

- eye pain, redness, or sensitivity to bright lights, blurred vision, floaters (dots that move across the field of vision)
- sudden headache, stiff neck, fever, sensitivity to bright light, drowsiness and muscle pain, with or without a rash
- unusual bleeding or bruising; repeated infections or infections that will not go away. This may be due to changes in your blood. Blood tests may be carried out to check for this
- yellowing of the skin or whites of the eyes caused by liver or blood problems.

Tell your doctor if you get any of the following side effects:

- muscle pain or muscle weakness
- nausea, vomiting or an upset stomach.
- skin rash or itching of the skin
- reactions to the sun. Skin may become red, painful and swollen- do not sunbathe, use a sun bed, or expose your skin to UV light.

Some people may get an increased amount of potassium in their blood (especially the elderly or those with kidney problems). You cannot feel or see this, but your doctor may test your blood for this side effect.

Reporting of side effects

If you get any side effects, talk to your doctor, pharmacist or nurse. This includes any possible side effects not listed in this leaflet. You can also report side effects directly via:

HPRA Pharmacovigilance

Website: www.hpra.ie

By reporting side effects you can help provide more information on the safety of this medicine.

5. HOW TO STORE TRIMETHOPRIM

Keep this medicine out of the sight and reach of children

Do not use this medicine after the expiry date which is stated on the label and carton after “EXP”. The expiry date refers to the last day of that month.

Store below 25°C.

Once opened, use within 3 months.

Do not throw away any medicines via wastewater or household waste. Ask your pharmacist how to throw away medicines you no longer use. These measures will help to protect the environment.

6. CONTENTS OF THE PACK AND OTHER INFORMATION

What Trimethoprim contains

The active substance is trimethoprim. Each ml of suspension contains 10 mg trimethoprim.

The other ingredients are:

Microcrystalline cellulose and Carmellose sodium, xanthan gum, methyl hydroxybenzoate sodium (E129), propyl hydroxybenzoate, liquid maltitol (E965), sodium saccharin, polysorbate 80, citric acid anhydrous, aniseed flavour PHL-140824, purified water.

What Trimethoprim looks like and contents of the pack

Trimethoprim oral suspension is a white opaque smooth suspension. It is available in 100ml amber glass bottles with tamper evident child resistant caps and an adapter. The dosing device is a 5ml

syringe with suitable markings which is enclosed in a cardboard carton with a PIL.

Marketing Authorisation Holder

Athlone Pharmaceuticals Limited,
Connaught House,
1 Burlington Road,
Dublin 4,
Ireland.

Manufacturer

Athlone Pharmaceuticals Ltd,
Maple House,
South County Business Park,
Dublin 18,
Ireland.

This leaflet was last revised in July 2025.